

© 1964 BY AMP INCORPORATED. ALL RIGHTS RESERVED. AMP PRODUCTS COVERED BY PATENTS AND/OR PATENTS PENDING. APPROVED PER GOVT CONTRACT NO.

LOCATION FOR AMP-TAB FEMALE CONTACT

LOCATION FOR KEYING PLUG 582501 -1 (FOR INTER-CONTACT KEYING)

REVISIONS				
ZONE	LTR	DESCRIPTION	DATE	APPROVED
G		REDRAWN 1/2 CHANGE, WAS SHOWN ON DWG 582714-ECN 1265	3-13-67	JA D.H.
H		REVISED ECN 2334	6-11-70	D.H.
J		REVISED 2334 AMEND. #1	9-3-70	D.H.
K		REVISED 6126 M.S.	7-26-79	
L		REVISED 8294 M.S.	1-83	
M		REVISED PER 0600-3683-95 TA	10-95	J. WARNER
N		ECO-08-020973	11-08	JW

582726-1 I. AS SHOWN.

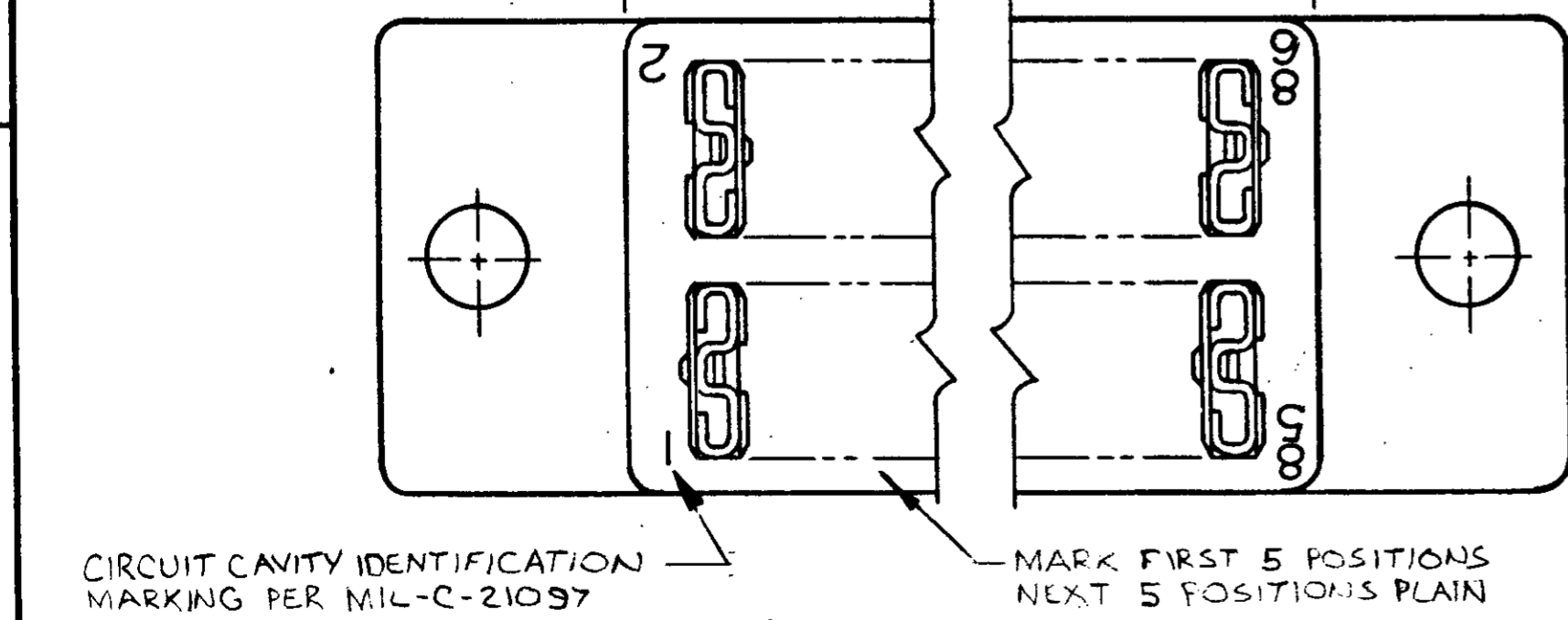
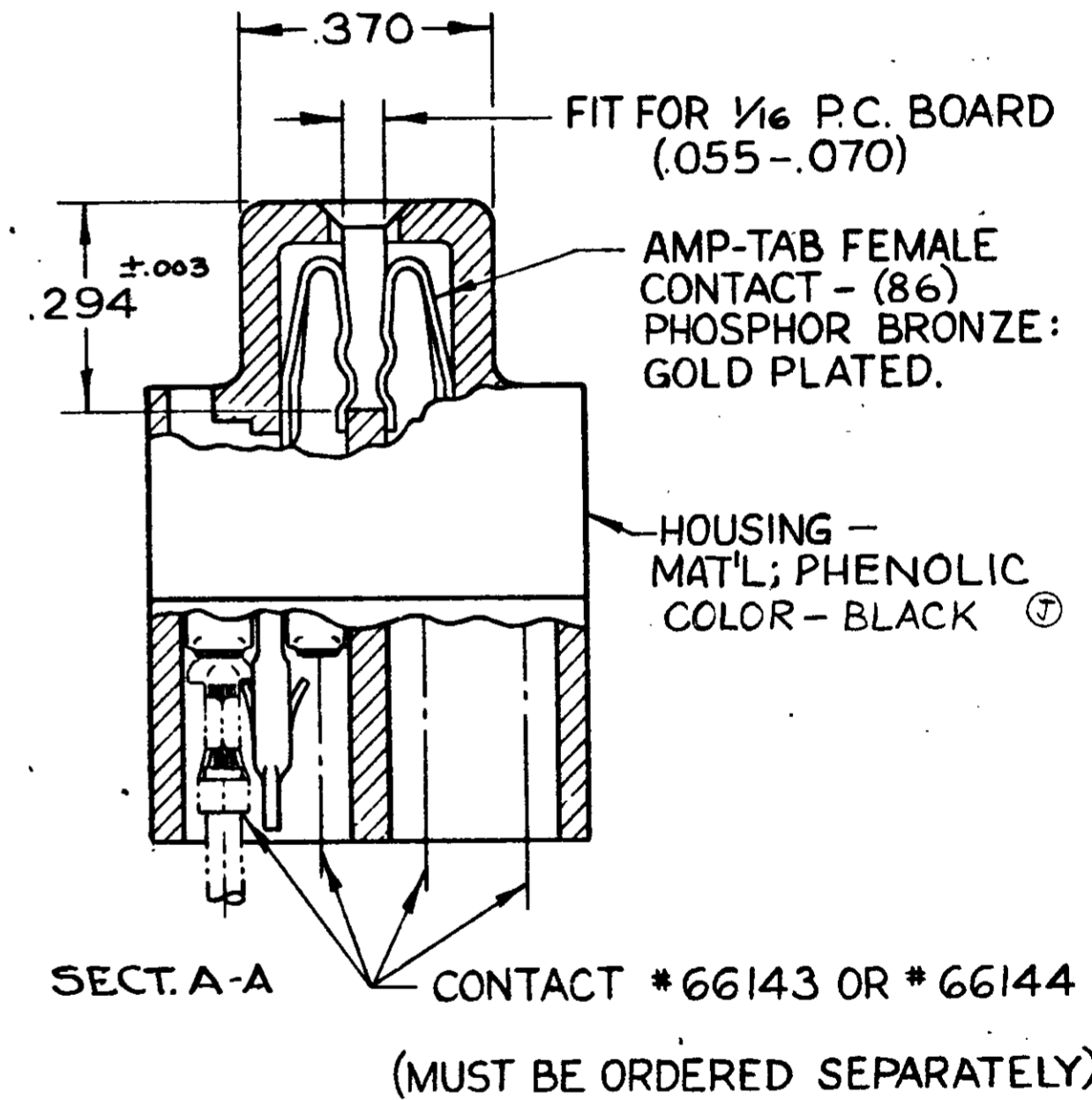
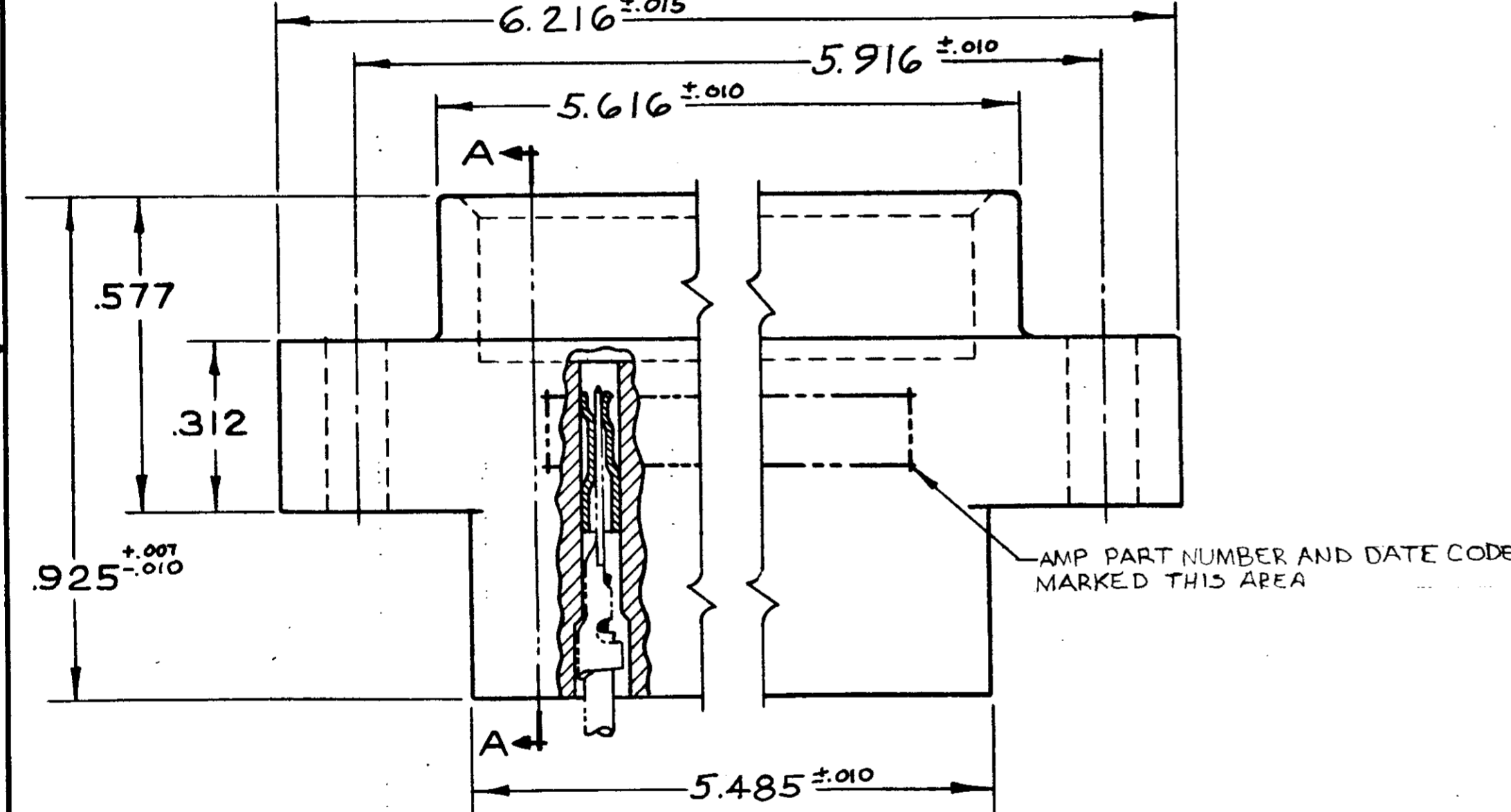
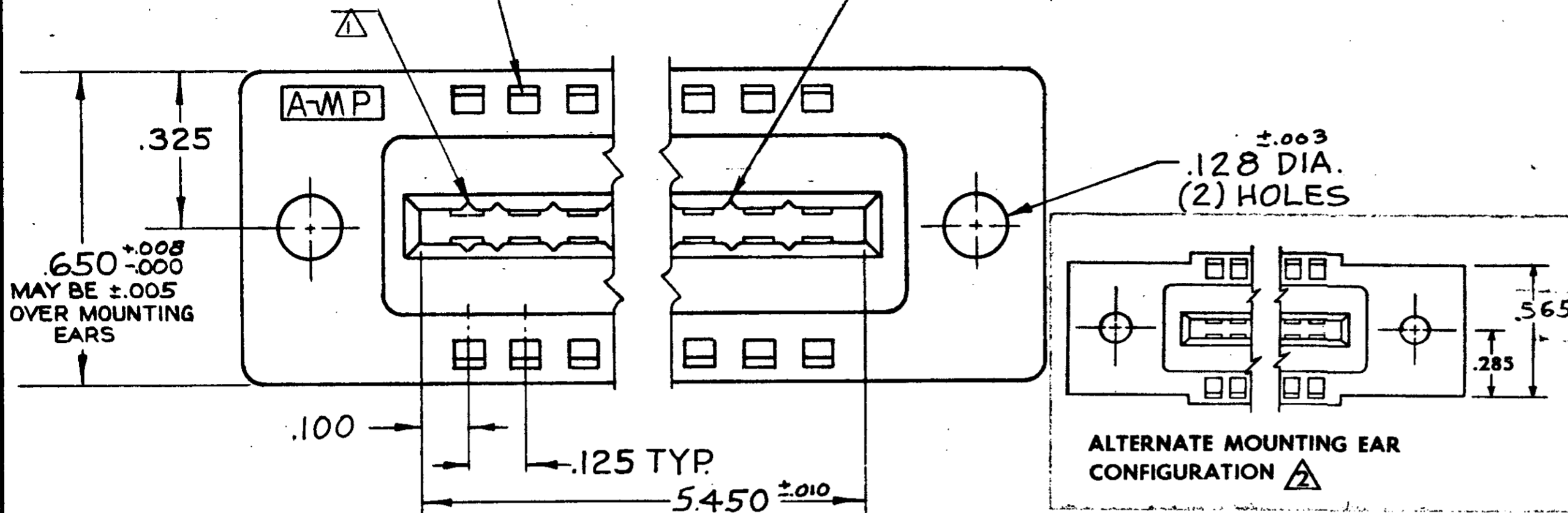

▲ GROOVES FOR "ON CONTACT KEYING" AMP'S OPTION DEPENDING ON METHOD OF MANUFACTURE FOR "ON CONTACT" KEYING USE KEYING PLUG P/N 583487-1. (MUST BE ORDERED SEPARATELY.)
 ▲ MOUNTING EAR CONFIGURATION AMP'S OPTION DEPENDS ON METHOD OF MANUFACTURE.

UNLESS OTHERWISE SPECIFIED DIMENSIONS ARE IN INCHES TOLERANCES ON		CONTRACT NO.		AMP INCORPORATED HARRISBURG, PENNSYLVANIA	
FRACTIONS ±	DECIMALS ±.005	ANGLES ±	DR g. asich	DATE 3-13-67	AMP TRADEMARK 43 POSITION AMP-TAB CONNECTOR .125 CENTERS QUAD
MATERIAL	SEE CALLOUT		CHK S.S. Heide	DATE 3/21/67	
HEAT TREAT	—		DSGN ENGR	DATE	
FINISH	SEE CALLOUT		APPD S Kaufman	DATE 3/21/67	
			DSGN APPD R Showman	DATE	SIZE C
			OTHER APPD		CODE IDENT NO 00779
					NUMBER 582726
					REV N
					SCALE 4 - WT CALC ACTUAL SHEET

3. LASER MARKING ACCEPTABLE FOR ALL MARKING

AMP INFO
LOC PRINT DIST
DF FQ

NUMBER
CUS. 582726